

Electric Hobs

N7E / N9E

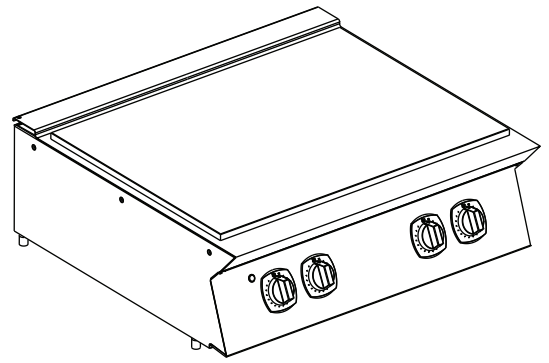

EN Installation and operating manual *



Foreword



The installation, use and maintenance manual (hereinafter Manual) provides the user with information necessary for correct and safe use of the machine (hereinafter “machine“ or “appliance“).

The following must not be considered a long and exacting list of warnings, but rather a set of instructions suitable for improving machine performance in every respect and, above all, preventing injury to persons and animals and damage to property due to improper operating procedures.

All persons involved in machine transport, installation, commissioning, use and maintenance, repair and disassembly must consult and carefully read this manual before carrying out the various operations, in order to avoid wrong and improper actions that could compromise the machine's integrity or endanger people. Make sure to periodically inform the user regarding the safety regulations. It is also important to instruct and update personnel authorised to operate on the machine, regarding its use and maintenance.

The manual must be available to operators and carefully kept in the place where the machine is used, so that it is always at hand for consultation in case of doubts or whenever required.

If, after reading this manual, there are still doubts regarding machine use, do not hesitate to contact the Manufacturer or the authorised Service Centre to receive prompt and precise assistance for better operation and maximum efficiency of the machine. During all stages of machine use, always respect the current regulations on safety, work hygiene and environmental protection. It is the user's responsibility to make sure the machine is started and operated only in optimum conditions of safety for people, animals and property.



IMPORTANT

- The manufacturer declines any liability for operations carried out on the appliance without respecting the instructions given in this manual.
- The manufacturer reserves the right to modify the appliances presented in this publication without notice.
- No part of this manual may be reproduced.
- This manual is available in digital format by:
 - contacting the dealer or reference customer care;
 - downloading the latest and up to date manual on the web site;
- The manual must always be kept in an easily accessed place near the machine. Machine operators and maintenance personnel must be able to easily find and consult it at any time.

Contents

A	SAFETY INFORMATION	4
A.1	General information	4
A.2	Personal protection equipment	4
A.3	General safety	5
A.4	General safety rules	6
A.5	Safety signs to be placed near the machine area	7
A.6	Transport, handling and storage	8
A.7	Installation and assembly	8
A.8	Electrical connection	8
A.9	Machine space limits	9
A.10	Positioning	9
A.11	Reasonably foreseeable improper use	10
A.12	Machine cleaning and maintenance	10
A.13	Machine disposal	11
B	TECHNICAL DATA	11
B.1	Appliance and manufacturer's identification data	11
B.2	Dataplate position	12
B.3	Technical data	12
C	GENERAL INFORMATION	12
C.1	Introduction	12
C.2	Intended use and restrictions	12
C.3	Testing and inspection	13
C.4	Copyright	13
C.5	Keeping the manual	13
C.6	Recipients of the manual	13
C.7	Definitions	13
C.8	Responsibility	13
D	NORMAL USE	13
D.1	Law requirements only for Australia	13
D.2	Characteristics of personnel trained for normal machine use	14
D.3	Characteristics of personnel enabled to operate on the machine	14
D.4	Operator qualified for normal machine use	14
E	INSTALLATION AND ASSEMBLY	14
E.1	Introduction	14
E.2	Customer's responsibilities	14
E.3	Disposal of packing	14
E.4	Joining Appliances	14
E.4.1	Installation On Bridge or Cantilever Frame (depending on the appliance and/or model)	14
E.4.2	Sealing Gaps Between Appliances	15
E.5	Safety thermostat	15
E.6	Electrical connections	15
E.6.1	Electric appliances	15
E.6.2	Power cable	15
E.6.3	Circuit breaker	15
E.6.4	Equipotential node and Earth connection	15
F	INSTRUCTION FOR THE USER	15
F.1	Introduction	15
F.2	Choosing pots/pans	16
F.3	Electrical models	16
F.3.1	Switching the appliance on	16
F.3.2	Switching the appliance off	16
G	MACHINE CLEANING AND MAINTENANCE	16
G.1	Ordinary maintenance	16
G.1.1	Precautions for maintenance	16
G.1.2	External parts	17
G.1.3	Other surfaces	17
G.1.4	Idle periods	17
G.1.5	Internal parts (every year)	17
G.1.6	Maintenance and schedule	17
G.1.7	Repair and extraordinary maintenance	18
G.1.8	Maintenance contacts (only for Australia)	18
H	MACHINE DISPOSAL	18
H.1	Waste storage	18
H.2	Procedure regarding appliance dismantling macro operations	18

A SAFETY INFORMATION

A.1 General information

To ensure safe use of the machine and a proper understanding of the manual it is necessary to be familiar with the terms and typographical conventions used in the documentation. The following symbols are used in the manual to indicate and identify the various types of hazards:



WARNING

Danger for the health and safety of operators.



WARNING

Danger of electrocution - dangerous voltage.



CAUTION

Risk of damage to the machine or the product.



IMPORTANT

Important instructions or information on the product



Read the instructions before using the appliance







Clarifications and explanations





- Only specialised personnel are authorised to operate on the machine.
- This appliance must not be used by minors and adults with limited physical, sensory or mental abilities or without adequate experience and knowledge regarding its use.
 - Do not let children play with the appliance.
 - Keep all packaging and detergents away from children.
 - Cleaning and user maintenance shall not be made by children without supervision.
- Do not store explosive substances, such as pressurized containers with flammable propellant, in this appliance or close to the appliance
- Do not remove, tamper with or make the machine “CE” marking illegible.
- Refer to the data given on the machine’s data plate “CE” marking for relations with the Manufacturer (e.g. when ordering spare parts, etc.).
- When scrapping the machine, the “CE” marking must be destroyed.

A.2 Personal protection equipment

Summary table of the Personal Protection Equipment (PPE) to be used during the various stages of the machine’s service life.

Stage	Protective garments 	Safety footwear 	Gloves 	Glasses 	Safety helmet 
Transport	—	●	○	—	○
Handling	—	●	○	—	—

Summary table of the Personal Protection Equipment (PPE) to be used during the various stages of the machine's service life. (cont'd.)

Stage	Protective garments 	Safety footwear 	Gloves 	Glasses 	Safety helmet 
Unpacking	—	●	○	—	—
Installation	—	●	○	—	—
Normal use	●	●	● ¹	—	—
Adjustments	○	●	—	—	—
Routine cleaning	○	●	○	○	—
Extraordinary cleaning	○	●	○	○	—
Maintenance	○	●	○	—	—
Dismantling	○	●	○	○	—
Scrapping	○	●	○	○	—
Key:					
●	PPE REQUIRED				
○	PPE AVAILABLE OR TO BE USED IF NECESSARY				
—	PPE NOT REQUIRED				

1. During Normal use, gloves must be heatproof to protect hands from contact with hot food or hot parts of the appliance and/or when removing hot items from it. Failure to use the personal protection equipment by operators, specialised personnel or users can involve exposure to chemical risk and possible damage to health (depending on the model).

A.3 General safety

- The machines are provided with electric and/or mechanical safety devices for protecting workers and the machine itself.
- Never operate the machine, removing, modifying or tampering with the guards, protection or safety devices.
- Do not make any modifications to the parts supplied with the appliance.
- Several illustrations in the manual show the machine, or parts of it, without guards or with guards removed. This is purely for explanatory purposes. Do not use the machine without the guards or with the protection devices deactivated.
- Do not remove, tamper with or make illegible the safety, danger and instruction signs and labels on the machine.
- Air recirculation must take into account the air necessary for combustion, 2 m³/h/kW of gas power, and also the “well-being” of persons working in the kitchen.
- Inadequate ventilation causes asphyxia. Do not obstruct the ventilation system in the place where this appliance is installed. Do not obstruct the vents or ducts of this or other appliances.
- Place emergency telephone numbers in a visible position.
- The A-weighted emission sound pressure level does not exceed 70 dB(A).
- Turn the appliance off in case of fault or poor operation.

- Do not use products (even if diluted) containing chlorine (sodium hypochlorite, hydrochloric or muriatic acid, etc.) to clean the appliance or the floor under it.
- Do not use metal tools to clean steel parts (wire brushes or Scotch Brite type scouring pads).
- Do not allow oil or grease to come into contact with plastic parts. Do not allow dirt, fat, food or other residuals to form deposits on the appliance.
- Do not spray water or use steam to clean the equipment.
- Do not store or use gasoline or other flammable vapours, liquids or items in the vicinity of this or any other appliance.
- Do not spray aerosols in the vicinity of this appliance while it is in operation.
- Never check for leaks with an open flame.

A.4 General safety rules

Protection devices installed on the machine

- The guards on the machine are:
 - fixed guards (e.g. casings, covers, side panels, etc.), fixed to the machine and/or frame with screws or quick-release connectors that can only be removed or opened with tools. Therefore the user must not remove or tamper with such devices. The Manufacturer declines any liability for damage due to tampering or their non-use.

Instructions for use and maintenance

- Risks mainly of a mechanical, thermal and electrical nature exist in the machine. Where possible the risks have been neutralised:
 - directly, by means of adequate design solutions.
 - indirectly by using guards, protection and safety devices.
- During maintenance several risks remain, as these could not be eliminated, and must be neutralised by adopting specific measures and precautions.
- Do not carry out any checking, cleaning, repair or maintenance operations on moving parts. Workers must be informed of this prohibition by means of clearly visible signs.
- To guarantee machine efficiency and correct operation, periodical maintenance must be carried out according to the instructions given in this manual.
- Make sure to periodically check correct operation of all the safety devices and the insulation of electrical cables, which must be replaced if damaged.
- Repair and extraordinary Maintenance have to be carried out by specialised authorised personnel provided with all the appropriate personal protection equipment, tools, utensils and ancillary means.
- Never operate the machine, removing, modifying or tampering with the guards, protection or safety devices.
- Before carrying out any operation on the machine, always consult the manual which gives the correct procedures and contains important information on safety.

Residual risks

- The machine has several risks that were not completely eliminated from a design standpoint or with the installation of adequate protection devices. Nevertheless, through this manual the Manufacturer has taken steps to inform operators of such risks, carefully indicating the personal protection equipment to be used by them. In order to reduce the risks, provide for sufficient spaces while installing the unit.

To preserve these conditions, the areas around the machine must always be:

- kept free of obstacles (e.g. ladders, tools, containers, boxes, etc.);
- clean and dry;

– well lit.

For the Customer's complete information, the residual risks remaining on the machine are indicated below: such situations are deemed improper and therefore strictly forbidden.

Residual risk	Description of hazardous situation
Slipping or falling	The operator can slip due to water or dirt on the floor
Burns/abrasions (e.g. heating elements)	The operator deliberately or unintentionally touches some components inside the machine without using protective gloves
Electrocution	Contact with live parts during maintenance operations carried out with the electrical panel powered
Sudden closing of the lid/door/oven door (if present, depending on the appliance type)	The operator for normal machine use could suddenly and deliberately close the lid/door/oven door (if present, depending on the appliance type)
Tipping of loads	When handling the machine or the packing containing it, using unsuitable lifting systems or accessories or with the unbalanced load

Mechanical safety characteristics, hazards





- The appliance does not have sharp edges or protruding parts. The guards for the moving and live parts are fixed to the cabinet with screws, to prevent accidental access.





IMPORTANT

In case of a significant anomaly (e.g. short circuits, wires coming out of the terminal block, motor breakdowns, worn electrical cable sheathing, etc.) the operator must immediately deactivate the machine.

A.5 Safety signs to be placed near the machine area

Prohibition	Meaning
	Do not remove the safety devices
	Do not use water to extinguish fires (placed on electrical parts)
	Keep the area around the appliance clear and free from combustible materials. Do not keep flammable materials in the vicinity of the appliance
	Install the appliance in a well-ventilated place to avoid the creation of dangerous mixtures of unburnt gases in the same room

Danger	Meaning
	caution, hot surface
	danger of electrocution (shown on electrical parts with indication of voltage)

End of use

- When the appliance is no longer to be used, make it unusable by removing the mains power supply wiring.

A.6 Transport, handling and storage

- Due to their size, the machines can be stacked on top of each other during transport, handling and storage by complying with that specified on the slip placed on the packing.
- Do not stand under suspended loads during loading/unloading operations. Unauthorised personnel must not enter the work area.
- The weight of the appliance alone is not sufficient to keep it steady.
- For machine lifting and anchoring, do not use movable or weak parts such as: casing, electrical raceways, pneumatic parts, etc.
- Do not push or pull the appliance to move it, as it may tip over.
- Machine transport, handling and storage personnel must be adequately instructed and trained regarding the use of lifting systems and personal protection equipment suitable for the type of operation carried out (e.g. overalls, safety shoes, gloves and helmet).
- When removing the anchoring systems, make sure the stability of the machine parts does not depend on the anchoring and, therefore, that this operation does not cause the load to fall off the vehicle. Before unloading the machine components, make sure all the anchoring systems are removed.
- Machine positioning, installation and disassembly must be carried out by specialised personnel.

A.7 Installation and assembly

- The operations described must be carried out by personnel qualified (refer to D.2 *Characteristics of personnel trained for normal machine use*) in compliance with the current safety regulations, regarding the equipment used and the operating procedures.
- The plug, if present, must be accessible after positioning the appliance in the place of installation.
- Disconnect the appliance from the power supply before carrying out any installation procedure.

A.8 Electrical connection

Before connecting, make sure the mains voltage and frequency match those indicated on the appliance data plate.

- Work on the electrical systems must only be carried out by specialised personnel.
- Connection to the power supply must be carried out in compliance with the regulations and provisions in force in the country of use.
- If the power cable is damaged, it must be replaced by the Customer Care Service or in any case by specialised personnel, in order to prevent any risk.

- Verify that a safety circuit breaker is installed between the power cable of the appliance and the mains electric line. The contact opening max. distance and leakage current must comply with the local safety regulations.
- Be sure to power the equipment with systems that are protected against overvoltage; the manufacturer declines all responsibility for effects due to anomalies induced by the electrical supply system.

A.9 Machine space limits

- A suitable space must be left around the appliance (for operations, maintenance, etc.).
- This space must be increased in case of use and/or transfer of other equipment and/or means or if exit routes are necessary inside the workplace.

A.10 Positioning

- Install the appliance, taking all the safety precautions required for this type of operation, also respecting the relevant fire-prevention measures.
- Handle the appliance with care in order to avoid damage or danger to people. Use a pallet for handling and positioning.
- The installation diagram gives the appliance overall dimensions and the position of connections (gas, electricity, water). Check that they are available and ready for making all the necessary connections.
- Prevent the areas where the machine is installed to be polluted with corrosive substances (chlorine, etc.). In case such prevention cannot be guaranteed, the entire stainless steel surface has to be coated by a paraffin protective film spread by using a rag soaked with paraffin. The manufacturer declines any liability for corrosive effects due to external causes.
- The appliance can be installed separately or combined only with other appliances of the same range.
- The appliances are not suitable for recess-mounting. Leave a space of at least 100 mm between the appliance and side walls and 100 mm from the rear wall, or in any case an adequate space to enable subsequent servicing or maintenance operations.
- Suitably insulate surfaces that are at distances less than that indicated.
- Maintain a distance of at least 200 mm between the appliance and any combustible walls. Do not store or use flammable materials and liquids near the appliance.
- Check and, if necessary, level the appliance after positioning. Incorrect levelling can cause appliance malfunctioning.
- Wear protective gloves and unpack the machine, carrying out the following operations:
 - cut the straps and remove the protective film, taking care not to scratch the surface if scissors or blades are used;
 - remove the cardboard top, the polystyrene corners and the vertical protection pieces;
 - for appliances with stainless steel cabinet, remove the protective film very slowly without tearing it, to avoid leaving glue stuck to the surface;
 - should this happen, remove the traces of glue with a non-corrosive solvent, rinsing it off and drying thoroughly;
 - go over all stainless steel surfaces vigorously with a cloth moistened with paraffin oil in order to create a protective film.
- In case of permanent connection: the device lockable in the open position must be accessible even after the appliance is installed in its place.

A.11 Reasonably foreseeable improper use

Improper use is any use different from that specified in this manual. During machine operation, other types of work or activities deemed improper and that in general can involve risks for the safety of operators and damage to the appliance are not allowed. Reasonably foreseeable improper use includes:

- lack of machine maintenance, cleaning and periodical checks;
- structural changes or modifications to the operating logic;
- tampering with the guards or safety devices;
- failure to use personal protection equipment by operators, specialised personnel and maintenance personnel;
- failure to use suitable accessories (e.g. use of unsuitable equipment or ladders);
- keeping combustible or flammable materials, or in any case materials not compatible with or pertinent to the work, near the machine;
- wrong machine installation;
- placing in the machine any objects or things not compatible with its use, or that can damage the machine, cause injury or pollute the environment;
- climbing on the machine;
- non-compliance with the requirements for correct machine use;
- other actions that give rise to risks not eliminable by the Manufacturer.
- The previously described actions are prohibited!



IMPORTANT

- In case of a significant anomaly (e.g. short circuits, wires coming out of the terminal block, motor breakdowns, worn electrical cable sheathing, smell of gas indicating possible leakage, etc.) the operator must:
 - immediately deactivate the machine and disconnect all the supplies (electricity, gas, water)

A.12 Machine cleaning and maintenance

- Before carrying out any cleaning or maintenance, disconnect the appliance from the power supply and carefully unplug it (if present).
- During maintenance, the cable and plug must be kept in a visible position by the operator carrying out the work.
- Do not touch the appliance with wet hands or feet or when barefoot.
- Do not remove the safety guards.
- Use a ladder with suitable protection for work on appliances with high accessibility (depending on the appliance type).
- Use suitable personal protection equipment (protective gloves). Refer to “A.2 *Personal protection equipment*” for suitable personal protection equipment.

Ordinary maintenance

- Disconnect the power supply before cleaning the appliance.
- Do not clean the machine with jets of water.

Precaution in case of long periods

- Machine maintenance, checking and overhaul operations must only be carried out by specialised personnel or the Customer Care Service, provided with adequate personal protection equipment (safety shoes and gloves), tools and ancillary means.

PNC	production number code
Ser.No.	serial number
Type	family type
EI	power supply voltage + phase
Hz	power supply frequency
kW	max. power input
A	current absorbed
Power unit EI.	power
I	dust and water protection rating
CE	CE marking
N	certification group
L	logo IMQ/GS
Electrolux Professional SpA Viale Treviso 15 33170 Porde- none Italy	manufacturer

B.2 Dataplate position



IMPORTANT

This instruction manual contains information relevant to various appliances.
See the dataplate located under the control panel to identify the appliance (see picture).

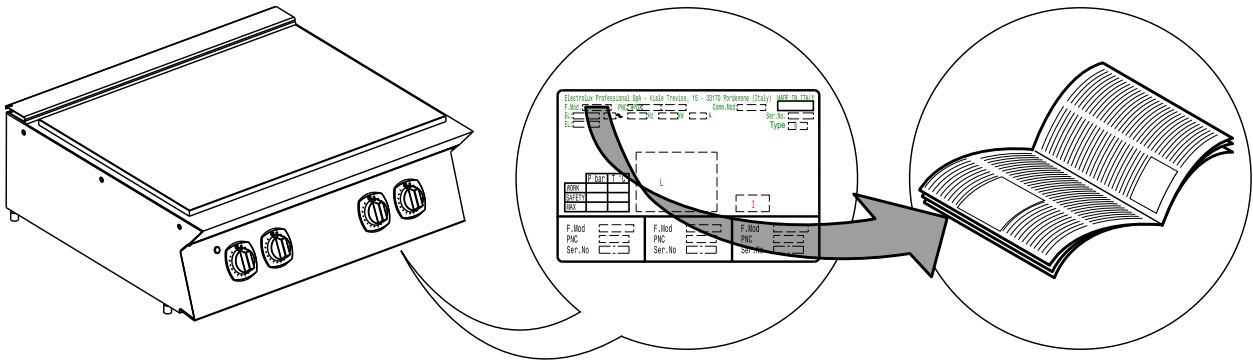

IMPORTANT

When installing the appliance, make sure the electrical connection is carried out in compliance with that specified on the data plate.

B.3 Technical data

N7E models

Models		Power supply voltage	Frequency	Phases	2.5 kW cooktop hotplates	Nominal max. Power	Power supply cable section ¹
		V	Hz		Nr.	kW	mm ²
+7HOED2000	400mm	400	50/60	3+N	2	5	1.5
+7HOEH4000	800mm	400	50/60	3+N	4	10	2.5

1. minimum recommended

N9E models

Models		Power supply voltage	Frequency	Phases	3.5 kW cooktop hotplates	Nominal max. Power	Power supply cable section ¹
		V	Hz		Nr.	kW	mm ²
+9HOED2000	400mm	400	50/60	3+N	2	7	1.5

1. minimum recommended

C GENERAL INFORMATION



WARNING

Refer to “*Safety Information*“.

terms used in the manual and useful information for the appliance user.

C.1 Introduction

Given below is some information regarding the intended use of this appliance, its testing, and a description of the symbols used (that identifies the type of warning), the definitions of

C.2 Intended use and restrictions

This appliance is designed for cooking food. It is intended for commercial use.

This appliance must not be used by minors and/or adults with limited physical, sensory or mental abilities or without adequate experience and knowledge regarding its use.

Children shall not play with the appliance. Cleaning and user maintenance shall not be made by children without supervision.



CAUTION

The machine is not suitable for installation outdoors and/or in places exposed to atmospheric agents (rain, direct sunlight, etc.).

C.3 Testing and inspection

Our appliances have been designed and optimized, with laboratory testing, in order to obtain high performance and efficiency.

Passing of the tests (visual inspection - gas/electrical test - functional test) is guaranteed and certified by the specific enclosures.

C.4 Copyright

This manual is intended solely for consultation by the operator and can only be given to third parties with the permission of Electrolux Professional SpA.

C.5 Keeping the manual

The manual must be carefully kept for the entire life of the machine, until scrapping. The manual must stay with the machine in case of transfer, sale, hire, granting of use or leasing.

C.6 Recipients of the manual

This manual is intended for:

- the carrier and handling personnel;
- installation and commissioning personnel;
- the employer of machine users and the workplace manager;
- operators for normal machine use;
- specialised personnel - Customer Care service (see service manual).

C.7 Definitions

Listed below are the definitions of the main terms used in the manual. It is advisable to read them carefully before use.

Operator	machine installation, adjustment, use, maintenance, cleaning, repair and transport personnel.
Manufacturer	Electrolux Professional SpA or any other service centre authorised by Electrolux Professional SpA.
Operator for normal machine use	an operator who has been informed and trained regarding the tasks and hazards involved in normal machine use.
Customer Care service or specialised personnel	an operator instructed/trained by the Manufacturer and who, based on his professional and specific training, experience and knowledge of the accident-prevention regulations, is able to appraise the operations to be carried out on the machine and recognise and prevent any risks. His professionalism covers the mechanical, electrotechnical and electronics fields etc.

Danger	source of possible injury or harm to health.
Hazardous situation	any situation where an operator is exposed to one or more hazards.
Risk	a combination of probabilities and risks of injury or harm to health in a hazardous situation.
Protection devices	safety measures consisting of the use of specific technical means (guards and safety devices) for protecting operators against risks.
Guard	an element of a machine used in a specific way to provide protection by means of a physical barrier.
Safety device	a device (other than a guard) that eliminates or reduces the risk; it can be used alone or in combination with a guard.
Customer	the person who purchased the machine and/or who manages and uses it (e. g. company, entrepreneur, firm).
Electrocution	an accidental discharge of electric current on a human body.

C.8 Responsibility

The Manufacturer declines any liability for damage and malfunctioning caused by:

- non-compliance with the instructions contained in this manual;
- repairs not carried out in a workmanlike fashion, and replacements with parts different from those specified in the spare parts catalogue (the fitting and use of non-original spare parts and accessories can negatively affect machine operation and invalidates the original manufacturer warranty);
- operations carried out by non-specialised personnel;
- unauthorized modifications or operations;
- missing, lack or inadequate maintenance;
- improper machine use;
- unforeseeable extraordinary events;
- use of the machine by uninformed and untrained personnel;
- non-application of the current provisions in the country of use, concerning safety, hygiene and health in the workplace.

The Manufacturer declines any liability for damage caused by arbitrary modifications and conversions carried out by the user or the Customer.

The employer, workplace manager or service technician are responsible for identifying and choosing adequate and suitable personal protection equipment to be worn by operators, in compliance with regulations in force in the country of use.

Electrolux Professional SpA declines any liability for inaccuracies contained in the manual, if due to printing or translation errors.

Any supplements to the installation, use and maintenance manual the Customer receives from the Manufacturer will form an integral part of the manual and therefore must be kept together with it.

D NORMAL USE



WARNING

Refer to “*Safety Information*”

D.1 Law requirements only for Australia

This appliance shall be installed only by authorised persons and in accordance with the manufacturer’s installation instructions, local gas fitting regulations, municipal building codes, electrical wiring regulations, local water supply regulations,

AS5601-gas installation, health authorities and any other statutory regulations.

D.2 Characteristics of personnel trained for normal machine use

The Customer must make sure the personnel for normal machine use are adequately trained and skilled in their duties, as well as ensuring their own safety and that of other persons.

The Customer must make sure his personnel have understood the instructions received and in particular those regarding work hygiene and safety in use of the machine.

D.3 Characteristics of personnel enabled to operate on the machine

The Customer is responsible for ensuring that persons assigned to the various duties:

- read and understand the manual;
- receive adequate training and instruction for their duties in order to perform them safely;

- receive specific training for correct machine use.

D.4 Operator qualified for normal machine use

Must have at least:

- knowledge of the technology and specific experience in operating the machine;
- adequate general basic education and technical knowledge for reading and understanding the contents of the manual, including correct interpretation of the drawings, signs and pictograms;
- sufficient technical knowledge for safely performing his duties as specified in the manual;
- knowledge of the regulations on work hygiene and safety.

In case of a significant anomaly (e.g. short circuits, wires coming out of the terminal block, motor breakdowns, worn electrical cable sheathing, etc.) the operator for normal machine use must:

- immediately deactivate the machine and disconnect all the supplies (electricity, gas, water).

E INSTALLATION AND ASSEMBLY



WARNING

Refer to “*Safety Information*”

E.1 Introduction

To ensure correct operation of the appliance and maintain safe conditions during use, carefully follow the instructions given below in this section.



CAUTION

Before moving the appliance make sure the load bearing capacity of the lifting equipment used is suitable for its weight.

E.2 Customer's responsibilities

The tasks and works required of the Customer are:

- prearrange a high-sensitivity manual-reset magneto-thermal circuit-breaker;
- prearrange a device lockable in the open position for the connection to the power supply.
- check the floor planarity on which the machine is placed.
- install a rapid gas shutoff valve ahead of each individual appliance (depending on the model). Install the valve in an easily accessed place.
- for information regarding the electrical connection, refer to E.6.1 *Electric appliances* paragraph;

E.3 Disposal of packing

The packing must be disposed of in compliance with the current regulations in the country where the appliance is used. All the packing materials are environmentally friendly.

They can be safely kept, recycled or burned in an appropriate waste incineration plant. Recyclable plastic parts are marked as follows:

 PE	Polyethylene <ul style="list-style-type: none"> • Outer wrapping • Instructions bag
 PP	Polypropylene <ul style="list-style-type: none"> • Straps
 PS	Polystyrene foam <ul style="list-style-type: none"> • Corner protectors

E.4 Joining Appliances

1. Undo the 4 fixing screws;
2. Remove the control panels of the appliances (Fig.1A);
3. Remove the fixing screw nearest the control panel, from each side to be joined (Fig.1B);
4. Bring the appliances together;
5. Turn the feet to level them until the tops match (Fig.1D);
6. Turn one of the two plates inside the appliances 180° (Fig.1C);

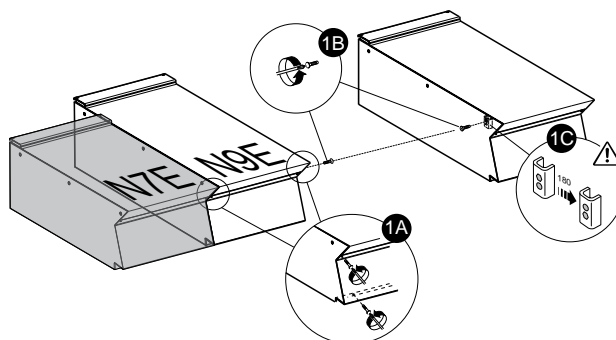

7. From inside the control panel of the same appliance, join them at the front side, screwing one M5x40 Hex Head screw (supplied) on the opposite insert (Fig.1E);
8. From the rear of the appliances, insert the coupling plate (provided) in the side slots on the back panels;
9. Secure the plate with two flat head M5 screws provided (Fig.1F).

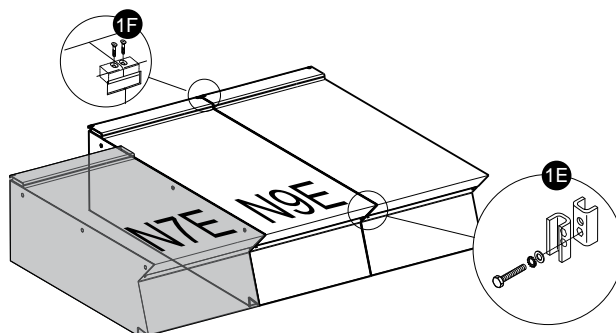

E.4.1 Installation On Bridge or Cantilever Frame (depending on the appliance and/or model)

- Carefully follow the instructions enclosed with the corresponding accessory.
- Follow the instructions supplied with the optional product chosen.

E.4.2 Sealing Gaps Between Appliances

Follow the instructions supplied with the optional sealing paste pack.

E.5 Safety thermostat

Appliances equipped with safety thermostat (overheating safety thermostat) that cuts in automatically when temperatures exceed a set value, shutting off the gas supply (gas appliances) or the electricity (electric appliances).



IMPORTANT

Resetting of the safety thermostat must be carried out by specialised personnel; contact the Service Centre.



IMPORTANT

“Positive trip“ effect safety thermostat (used on some equipment type as per norms prescriptions) interrupts the unit operability (heating) even in case the capillary is cut.

Similar effect, but with no damage for the safety thermostat, can happen if the machine body temperature drops below -10°C: in such cases, it is required to reset the safety thermostat while installing the machine, hence before connecting it to the mains.



IMPORTANT

On electric heated machines, only reset safety thermostat after disconnecting from the mains. Failure to disconnect from the mains causes the safety thermostat to brake and the unskilled person to risk electrocution.

Tampering with the safety thermostat invalidates the original manufacturer warranty.

E.6 Electrical connections

E.6.1 Electric appliances



WARNING

Before connecting, make sure the mains voltage and frequency match those indicated on the appliance data plate.

To access the terminal board:

1. Undo the fixing screws.
2. Remove the appliance front panel.

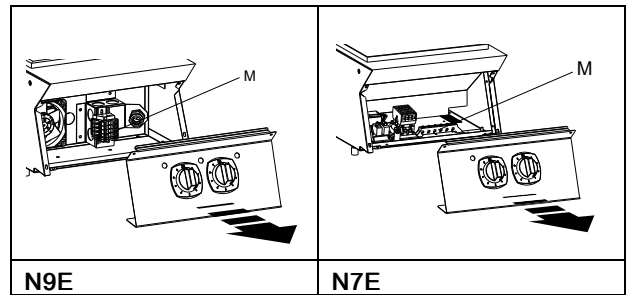

3. Connect the power cable to the terminal block “M” according to the wiring diagram provided with the appliance.
4. Secure the power cable with the cable clamp.
5. Refit the appliance front panel.



IMPORTANT

The manufacturer declines any liability if the safety regulations are not respected.

E.6.2 Power cable

Unless otherwise specified, our appliances are not equipped with a power cable.

The installer must use a flexible cable having characteristics not lower than the H07RN-F rubber insulated type.

Protect the section of cable outside the appliance with a metal or rigid plastic tube.

E.6.3 Circuit breaker

Verify that a safety circuit breaker is installed between the power cable of the appliance and the mains electric line.

The contact opening max. distance and leakage current must comply with the local safety regulations.

E.6.4 Equipotential node and Earth connection

Connect the appliance to an earth;

it must be included in an equipotential node by means of the screw located at the front right under the frame.

The screw is marked with the symbol

F INSTRUCTION FOR THE USER

F.1 Introduction

N9E models

- The 1/2 module (400 mm) cooking top features two 3500 W hot plates.
- The 1 module (800 mm) cooking top features four 3500 W hot plates.

Each plate comprises two concentric heating elements (1750 W, each);

The wide temperature range of the plates (from 80°C to approx. 400°C) makes the appliance particularly versatile:

- **Maintenance:** low temperatures 80-100°C;
- **Cooking (with recipients, such as pots and pans):** up to 400°C as necessary.

N7E models

- The 1/2 module (400 mm) cooking top features two 2500 W hot plates.
- The 1 module (800 mm) cooking top features four 2500 W hot plates.

The wide temperature range of the plates (from 120°C to approx. 440°C) makes the appliance particularly versatile:

- **Maintenance:** low temperatures 120-140°C;
- **Cooking (with recipients, such as pots and pans):** up to 440°C as necessary.



CAUTION

Do not cook foods directly on hot plates (e.g. meat)

To ensure correct, energy-saving operation, observe the following rules:

- Position the pot/pan before switching on the hot plate;
- Do not leave the hot plate on when the pot/pan is empty or has been removed;
- Do not allow wet the plate with cold liquids when it is hot.



NOTE!
All plates are equipped with an overtemperature limiter.

It automatically cuts off the electricity supply when maximum temperature is reached, then restores it when the plate begins to cool.

F.2 Choosing pots/pans

Make sure that the bottom of the pot/pan is clean and dry before use.

- Optimal thickness for stainless steel recipients is 4-6 mm.
- The bottom of cooking recipients should be perfectly flat to ensure even distribution of heat.

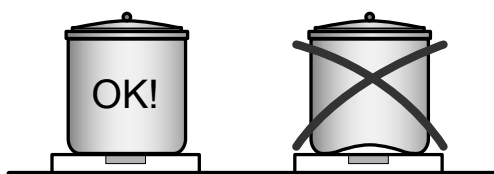

F.3 Electrical models

F.3.1 Switching the appliance on

N9E models

The knob may be set to the following positions:

0	= plate off
1	= minimum heating
2 – 8	= medium heating

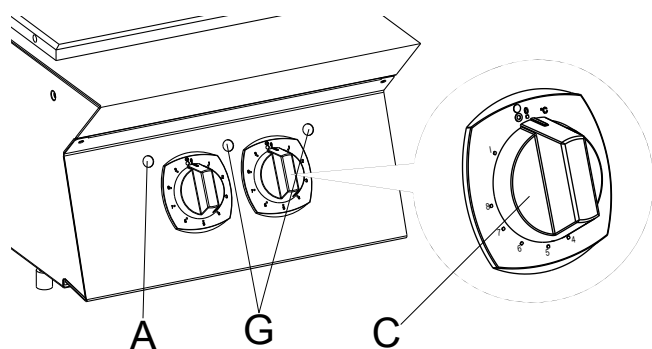

To switch the appliance on:

1. Turn the appliance on at the main switch.
2. To switch on a hot plate, rotate the relative knob "C" to the required setting.



NOTE!

The appliance is powered up when the green indicator lamp "A" is on.

In this way the first of the two concentric heating elements of each plate is switched on.

To switch on both elements on each plate

1. Rotate the knob "C" over the maximum heating position (position "I");
2. Then rotate it back to the required heating setting.
The yellow lamp "G" will light up when both heating elements are switched on.
3. To keep just one element on, turn the knob to "0", then to the heating level required.

N7E models

The knob may be set to the following positions:

0	= plate off
1	= 120 °C
2	= 160 °C
3	= 200 °C
4	= 240 °C
5	= 280 °C
6	= 320 °C
7	= 360 °C
8	= 400 °C
9	= 440 °C

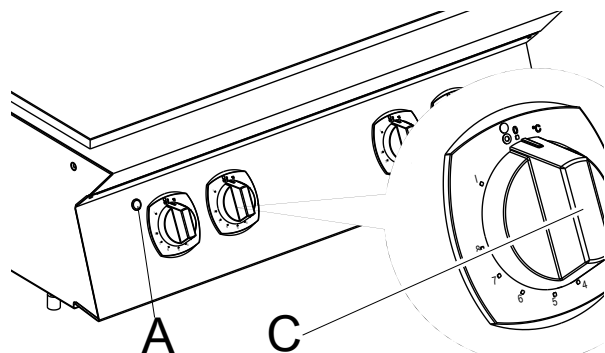

To switch the appliance on:

1. Turn the appliance on at the main switch.
2. To switch on a hot plate, rotate the relative knob "C" to the required setting.
The appliance is powered up when the green indicator lamp "A" is on.

F.3.2 Switching the appliance off

1. Turn the control knob "C" to "0" position.
2. Turn off the appliance at the main switch.



NOTE!

Plates may remain hot for some time after the appliance has been switched off.

G MACHINE CLEANING AND MAINTENANCE



WARNING

Refer to "Safety Information".

G.1 Ordinary maintenance

G.1.1 Precautions for maintenance

Routine maintenance operations can be carried out by non-specialised personnel, carefully following the instructions given below.



CAUTION

Before carrying out any cleaning operation, disconnect the appliance from the power supply.

Do not use ice or water to quickly cool the cooking plate.

Do not use ice or water for cleaning when the cooking plate is hot since, this will permanently deform it and compromise appliance operation.



NOTE!

Improper cleaning automatically invalidates the warranty.

G.1.2 External parts

SATIN-FINISH STEEL SURFACES (daily)

- Clean all steel surfaces: dirt is easily removed when it has just formed.
- Remove grime, fat and other cooking residuals from steel surfaces when cool using soapy water, with or without detergent, and a cloth or sponge.
Dry the surfaces thoroughly after cleaning.
- In case of encrusted grime, fat or food residuals, go over with a cloth or sponge, wipe in the direction of the satin finish and rinse often:
Rubbing in a circular motion combined with the particles of dirt on the cloth/sponge could spoil the steel's satin finish.
- Metal objects can spoil or damage the steel: damaged surfaces become dirty more easily and are more subject to corrosion.
- Restore the satin finish if necessary.

SURFACES BLACKENED BY HEAT (when necessary)

- Exposure to high temperatures can cause the formation of dark marks.
These do not constitute damage and can be removed by following the instructions given in the previous section.

G.1.3 Other surfaces

Surfaces in mild steel or cast iron (daily)

- Remove dirt using a damp cloth or, in the event of encrustations, the accessories (optional or supplied) specified in the list;

G.1.6 Maintenance and schedule

All the components requiring maintenance are accessible from the front or the rear panel of the appliance.

Maintenance frequency

- Machine maintenance, checking and overhaul operations must only be carried out by a specialised Technician or the Customer Care Service, provided with adequate personal protection equipment (safety shoes and gloves), tools and ancillary means.
- Work on the electrical equipment must only be carried out by a specialised electrician or the Customer Care Service.
- To ensure constant machine efficiency, it is advisable to carry out the checks with the frequency given in the following table:

Maintenance, inspections, checks and cleaning	Frequency	Responsibility
Ordinary cleaning • general cleaning of machine and surrounding area.	Daily	Operator
Mechanical protection devices • check their condition and for any deformation, loosening or removed parts.	Yearly	Service
• Control check the mechanical part, for cracks or deformation, tightening of screws: check the readability and condition of words, stickers and symbols and restore if necessary.	Yearly	Service
Machine structure • tightening of main bolts (screws, fixing systems, etc.) of machine.	Yearly	Service
• Safety signs check the readability and condition of safety signs.	Yearly	Service

- After cleaning, switch the appliance on to dry the surface quickly;
- Protect the surface with a light film of cooking oil.



NOTE!

Do not use metal scrapers or other objects that could damage the surface.

Scratches on the plate will permanently compromise its functionality and cleanability.

G.1.4 Idle periods

If the appliance is not going to be used for some time, take the following precautions:

- Close the valves or main switches ahead of the appliances;
- Go over all stainless steel surfaces vigorously with a cloth moistened with paraffin oil in order to create a protective film;
- Periodically air the premises;
- Have the appliance checked before using it again;
- For the electric heated models: switch the machine On at the minimum rate of heat for at least 45 minutes; this will allow moisture/humidity accumulated into the heating elements to evaporate without damaging the elements.

G.1.5 Internal parts (every year)



IMPORTANT

Operations to be carried out only by specialised personnel.

- Check the condition of the internal parts.
- Remove any deposits of dirt inside the appliance.
- Check and clean the discharge system.



IMPORTANT

In particular conditions (e.g. intensive use of the appliance, salty environment, etc.) the above cleaning should be more frequent.

Maintenance, inspections, checks and cleaning	Frequency	Responsibility
<ul style="list-style-type: none"> Electrical control panel check the electrical components installed inside the electrical control panel. Check the wiring between the electrical panel and machine parts. 	Yearly	Service
<ul style="list-style-type: none"> Electrical connection cable and plug check the connection cable (replace if necessary) and plug. 	Yearly	Service
<ul style="list-style-type: none"> Extraordinary machine maintenance check all gas components (if present). 	Yearly	Service
General machine overhaul <ul style="list-style-type: none"> check all components, electrical equipment, corrosion, pipes... 	Every 10 years ¹	Service

1. the machine is designed and built for a duration of about 10 years. After this period of time (from commissioning) the machine must undergo a general inspection and overhaul. Some examples of checks to be carried out are given below.

- Check for any oxidised electrical components or parts; if necessary, replace them and restore the initial conditions;
- Check the structure and welded joints in particular;
- Check and replace bolts and/or screws, also checking for any loose components;
- Check the electrical and electronic system;
- Check the functionality of safety devices;
- Check the general condition of protection devices and guards.



NOTE!

It is advisable to stipulate a preventive and scheduled maintenance contract with the Customer Care Service.

Disassembly

- All scrapping operations must occur with the machine stopped and cold and the electrical power supply disconnected.
- Work on the electrical equipment must only be carried out by a qualified electrician, with the power supply disconnected.
- To carry out these operations it is necessary to use: overalls, safety shoes and gloves.
- During disassembly and handling of the various parts, the minimum height from the floor must be maintained.

G.1.7 Repair and extraordinary maintenance



NOTE!

Repair and extraordinary maintenance have to be carried out by specialised authorised personnel, who can ask the manufacturer to supply a servicing manual.

- Electrolux - Tom Stoddart Pty Ltd — 39 Forest Way, Karawatha QLD 4117 — call 1-300-307-289
- Zanussi - Procook Australia Pty Ltd — 23 Rothesay Street, Kenmore, Queensland 4069 — call 07-3868-4964
- Diamond - Semak Food Service Equipment — 18, 87-91 Hallam South Road, Hallam VIC 3803 — call 03 9796 4583

G.1.8 Maintenance contacts (only for Australia)

For service and spare parts, please contact:

H MACHINE DISPOSAL



WARNING

Refer to “*Safety Information*“

H.1 Waste storage

At the end of the product's life-cycle, make sure it is not dispersed in the environment. The doors must be removed before scrapping the appliance.

SPECIAL waste materials can be stored temporarily while awaiting treatment for disposal and/or permanent storage. In any case, the current environmental protection laws in the user's country must be observed.

H.2 Procedure regarding appliance dismantling macro operations

Before disposing of the machine, make sure to carefully check its physical condition, and in particular any parts of the structure that can give or break during scrapping.

The machine's parts must be disposed of in a differentiated way, according to their different characteristics (e.g. metals, oils, greases, plastic, rubber, etc.).

Different regulations are in force in the various countries, therefore comply with the provisions of the laws and competent bodies in the country where scrapping takes place.

In general, the appliance must be taken to a specialised collection/ scrapping centre.

Dismantle the appliance, grouping the components according to their chemical characteristics, remembering that the compressor contains lubricant oil and refrigerant fluid which can be recycled, and that the refrigerator components are special waste assimilable with urban waste.



The symbol on the product indicates that this product should not be treated as domestic waste, but must be correctly disposed of in order to prevent any negative consequences for the environment and human health. For further information on the recycling of this product, contact the local dealer or agent, the Customer Care service or the local body responsible for waste disposal.



NOTE!

When scrapping the machine, any marking, this manual and other documents concerning the appliance must be destroyed.

CE

Electrolux Professional SPA
Viale Treviso 15
33170 Pordenone
www.electrolux.com/professional